



TEREX

Port Solutions

TEREX FLT-FDC450S4

With forks in standard position

TECHNICAL SCHEDULE

				Metric		Imperial	
1	Capacity	Q	Rated Capacity on forks	Kg	45000	lbs	99000
1a	Capacity	Q	Rated Capacity under spreader at 3rd height	Kg	38000	lbs	83600
1b	Capacity	Q	Rated Capacity under spreader at 4th height	Kg	31000	lbs	68200
2	Load Centre	C	Distance	mm	1225	ln	48
3	Dimensions	h3	Lifting Height	mm	12500	ln	492
4		h2	Free lift	mm	-	ln	-
5		h8	Lifting height under Twist-locks	mm	4 x 9'6" with forks in standard position		
6		α / β	Mast tilting (Forward / Reverse)	°	5 / 12		
7		y	Wheel base	mm	5750	ln	226
8		S1 / S2	Wheel centre F/R	mm	3370 / 2580	ln	132 / 101
9		m1	Ground clearance lowest point (loaded)	mm	350	ln	14
10		m2	Ground clearance mid track (loaded)	mm	550	ln	22
11		L	Length	mm	8000	ln	315
12		B / B1	Overall width (Front / Rear)	mm	4200 / 3100	ln	165 / 122
13		h1	Closed Mast Height	mm	8900	ln	350
14		h4	Open Mast Height	mm	15150	ln	596
15		h6	Cabin Height	mm	4600	ln	181
16		h7	Seat Height	mm	3500	ln	138
17	P	Rear Overhang	mm	950	ln	37	
18	W1 / Wa	Turning radius (Inside / Outside)	mm	975 / 7800	ln	38 / 307	
19	x	Distance from C/L of front axle to face of machine	mm	1300	ln	51	
20	Mast design		Type	DUPLEX			
21	Forks		Thickness x width x length (F1 x F2 x F3)	mm	150 x 300 x 2450	ln	5,906 x 11,8 x 96,457
22		B2	Max distance external forks	mm	3150	ln	124
23		B3	Min distance external forks	mm	1350	ln	53
24			Sideshift ±	mm	450 / 450	ln	18 / 18
25	Speeds		Travel With / Without Load	Km/h	24 / 25	mph	15,0 / 15,6
26			Lift With / Without Load	m/s	0,20 / 0,26	ft/min	39,4 / 51,2
27			Lowering With / Without Load	m/s	0,25 / 0,21	ft/min	49,2 / 41,3
28	Tires		V = Solid - L = Pneum	F / R	L / L		
29			N° of tire (Front / Rear)		4 / 2		
30			Size Front		18.00 x 25		
31			Size Rear		18.00 x 25		
32			Inflation Pressure	bar	10	psi	145
33		Ground pressure	kg/cm ²	9	psi	131	
34	Max. Drawbar pull		Loaded	daN	30000	lbf	66000
35	Max. Gradient		Loaded	%	30		
36	Total Weight		Unloaded	Kg	72000	lbs	158400
37			Loaded	Kg	110000	lbs	242000
38	Weight on axle	F / R	Loaded	Kg	101500 / 8500	lbs	223300 / 18700
39		F / R	Unloaded	Kg	47000 / 25000	lbs	103400 / 55000
40	Brakes	Front	Pedal servohydraulic		Wet Disc Brakes		
41		Parking	Mechanical		Disc on transmission		
42	Engine		Type	Water cooled turbo diesel			
43			Manufacturer / Type	CUMMINS QSM11			
44			Emission regulation	U.S. EPA Tier 3, CARB Tier 3, EU Stage IIIA			
45			Continuous power	Kw	250		
46			Revolutions per minute	rpm	2000		
47			Number of Cylinders / Displacement	cm ³	6 / 10800		
48			Maximum torque	Nm @ rpm	1674 @ 1400		
49		Effective fuel consumption	l/h				
50	Batteries		Voltage / Capacity	V / Ah	24 / 150		
51	Drive axle		Brand	Kessler D102 PL341 - NLB			
52			Type	With planetary reducer hub and removable half-shaft			
53	Steering axle		Type	Servo assisted oscillating single equalizer cylinder			
54	Transmission		Brand	DANA/CLARK			
55			Model	36415			
56			Gear Speed (Forward / Reverse)	4 / 4			
57			Type	HYDRODYNAMIC WITH TORQUE CONVERTER			
58	Clutch		Type	POWER-SHIFT			
59	Hydraulic Pressure		Operating	bar	180	psi	2611
60	Fluid Capacities		Hydraulic oil	Liters	670	gals	177
61			Fuel	Liters	520	gals	137
62	Noise level		Outside Cabin / Inside Cabin	db (A)	85 / 75		
63	Stability Factor		Static	1,5			

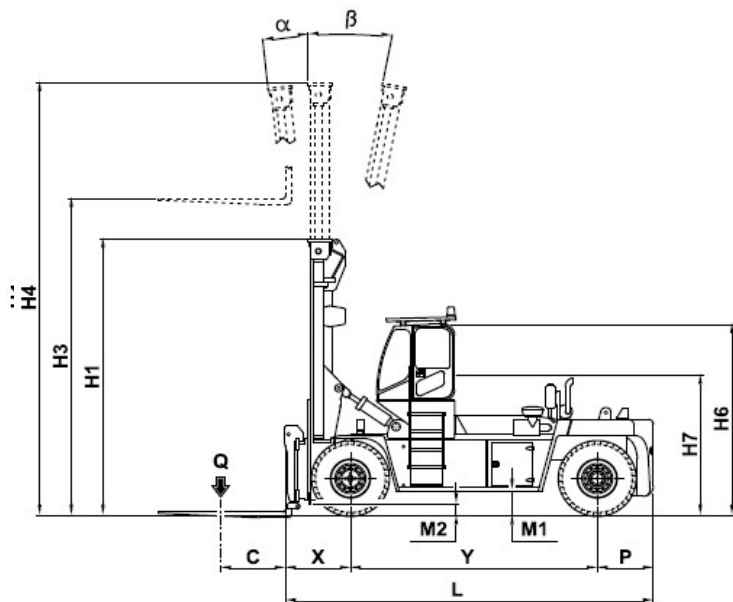

SIDESHIFT AND FORKS POSITIONING

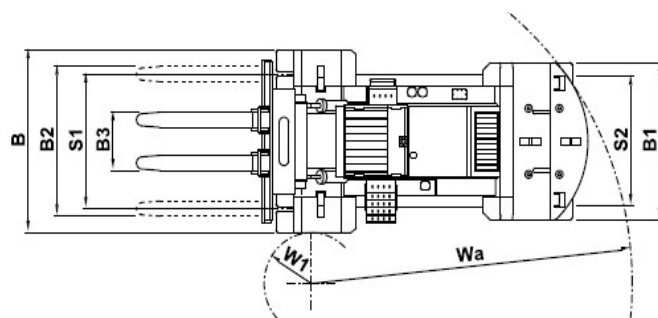
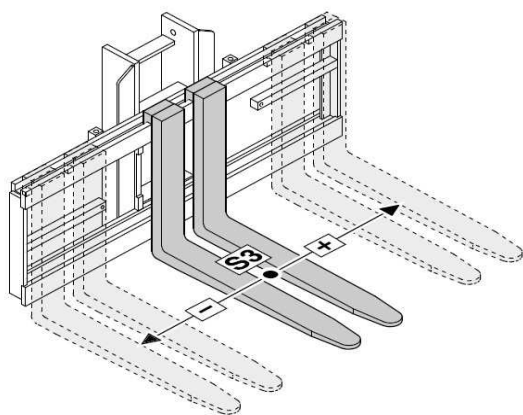

FORK DIMENSIONS

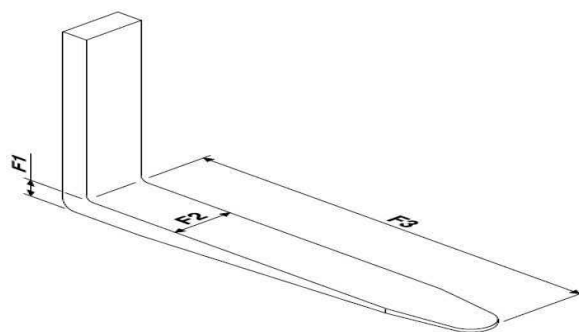

MAIN DIMENSIONS

		Metric		Imperial	
Q	Rated Capacity on forks	Kg	45000	lbs	99000
Q	Rated Capacity under spreader at 3rd height	Kg	38000	lbs	83600
Q	Rated Capacity under spreader at 4th height	Kg	31000	lbs	68200
C	Distance	mm	1225	ln	48
x	Distance from front axle centre to load	mm	1300	ln	51
y	Wheel base	mm	5750	ln	226
P	Rear Overhang	mm	950	ln	37
L	Length	mm	8000	ln	315
h1	Closed Mast Height	mm	8900	ln	350
h3	Lifting Height	mm	12500	ln	492
h4	Open Mast Height	mm	15150	ln	596
h6	Cabin Height	mm	4600	ln	181
h7	Seat Height	mm	3500	ln	138
h8	Lift under Twist-locks (Triple mast opt.)	mm	with forks in standard	ln	//
m1	Ground clearance lowest point (loaded)	mm	350	ln	14
m2	Ground clearance mid track (loaded)	mm	550	ln	22
a / b	Mast tilting (Forward / Reverse)	°	5 / 12		
B / B1	Width Front / Rear	mm	4200 / 3100	ln	165 / 122
S1 / S2	Wheel centre F/R	mm	3370 / 2580	ln	132 / 101
W1 / Wa	Turning radius (Internal / External)	mm	975 / 7800	ln	38 / 307