



reddot design award  
winner 2012



Let's grow together 

# EPT20-15ET

## Electric Pallet Truck 1.5t

- 1st Innovative Design Ever
- Compact Size & Light Weight, Convenient for Operation
- Energy-saving & environment-friendly design maximizes running time
- Incredible Market Share Globally

EP EQUIPMENT CO.,LTD  
[www.ep-ep.com](http://www.ep-ep.com)

# ▣ FEATURE

## ■ Innovation:

1st Innovative Design Ever won the REDDOT award.



reddot design award  
winner 2012

## ■ Light Weight, Great Capacity, Great Passingability:

Light weight & compact size create excellent maneuverability & passingability.  
1500KG capacity handles most applications.



## ■ Anti-vibration Technology for Batteries:

Special anti-vibration technology extends maintenance-free battery life.

## ■ Cables:

Robot cables with excellent twist resistance offers longer life span.

## ■ Charger:

Charger with temperature indicator protects battery.

## ■ Operation:

Ergonomically-designed tiller head helps increase efficiency; Internal Charger for Easy Charging.

## ■ Safety:

Handy Emergency Disconnect Button & Durable Driving Unit ensure safety under any situation.

## ■ Serviceability:

Assembly Components, Easy for Diagnosis and Replacing.



# Electric Pallet Truck 1.5t

## EPT20-15ET

Distinguishing mark			
1.1	Manufacturer		EP
1.2	Model designation		EPT20-15ET
1.3	Drive unit		Electrics
1.4	Operator type		pedestrian
1.5	rated capacity	Q kg	1500
1.6	Load center distance	c mm	600
1.8	Load distance	x mm	889/946
1.9	Wheelbase	y mm	1268/1231
Weight			
2.1	Service weight (include battery)	kg	205
2.2	Axle loading, laden driving side/loading side	kg	550/1155
2.3	Axle loading, unladen driving side/loading side	kg	180/25
Types,Chassis			
3.1	Tyre type driving wheels/loading wheels		PU/ PU
3.2	Tyre size, driving wheels ( diameter×width )	mm	Φ210x70
3.3	Tyre size, loading wheels ( diameter×width )	mm	2x Φ80x60 ( Φ74x88 )
3.4	Tyre size, caster wheels ( diameter×width )	mm	/
3.5	Wheels, number driving , caster/loading (x=drive wheels)	mm	1x /4 ( 1x /2 )
3.6	Track width, front,driving side	b <sub>10</sub> mm	/
3.7	Track width,rear,loading side	b <sub>11</sub> mm	410 ( 535 )
Dimensions			
4.4	Lift height	h <sub>3</sub> mm	115
4.9	Height drawbar in driving position min./max.	h <sub>14</sub> mm	750/1170
4.15	Lowered height	h <sub>13</sub> mm	85 ( 75 )
4.19	Overall length	l <sub>1</sub> mm	1632
4.20	Length to face of forks	l <sub>2</sub> mm	482
4.21	Overall width	b <sub>7</sub> / b <sub>2</sub> mm	560 ( 685 )
4.22	Fork dimensions	s/ e/ l mm	50/150/1150
4.25	Distance between fork-arms	b <sub>5</sub> mm	560 ( 685 )
4.32	Ground clearance, center of wheelbase	m <sub>2</sub> mm	35
4.34.1	Aisle width for pallets 1000 × 1200 crossways	Ast mm	1739
4.34.2	Aisle width for pallets 800 × 1200 lengthways	Ast mm	1939
4.35	Turning radius	Wa mm	1485
Performance data			
5.1	Travel speed, laden/ unladen	km/ h km/h	4/4.5
5.2	Lifting speed, laden/ unladen	m/ s	0.026/0.031
5.3	Lowering speed, laden/ unladen	m/ s	0.029/0.021
5.8	Max. gradeability, laden/unladen		2/6
5.10	Service brake type		Electromagnetic
Electric-engine			
6.1	Drive motor rating S2 60 min	kW	0.65
6.2	Lift motor rating at S3 15%	kW	0.84
6.3	The maximum allowed size battery	mm	265*185*215
6.4	Battery voltage/nominal capacity K20		24/85
6.5	Battery weight	kg	25.5x2
Addition data			
8.1	Type of drive control		DC
10.5	Steering type		Mechanical
10.7	Sound pressure level at the driver's ear		74

1.The parameters in the table are of the standard model. For more information, please contact us.

2.The parameters are subject to change without notice.

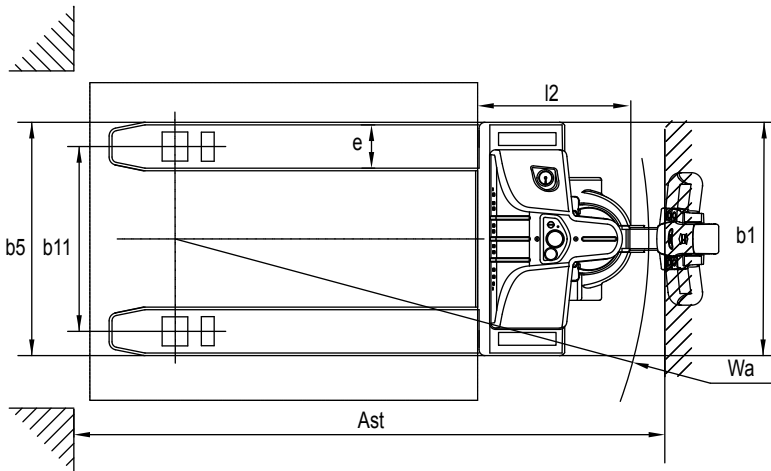
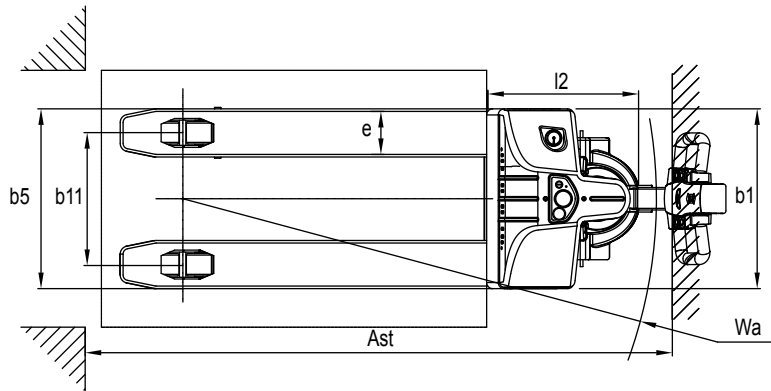
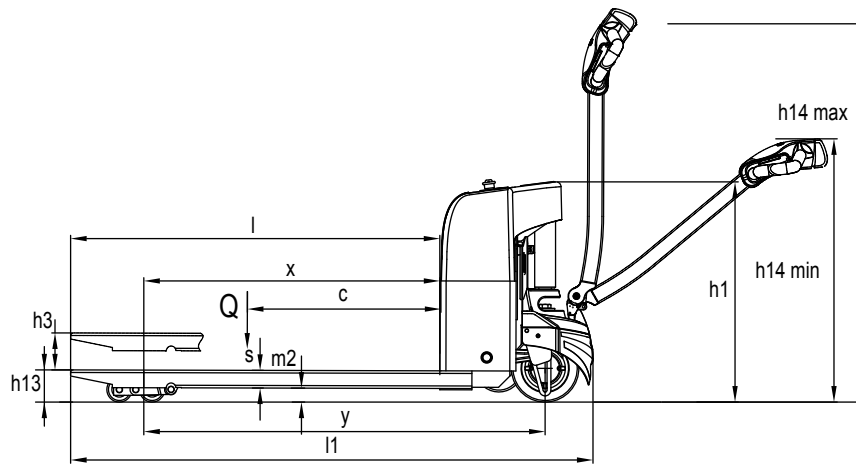

## Option

Options	EPT20-15ET
Fork length	●800/915/1000/1070/1100/1300/1400mm
Fork width	●460/520/600mm
Single load wheel	•
Fork lowered height	●75mm (Capacity <=1000kg)
Driving wheel	PU wheel with Pattern
Balance wheel	•
Battery capacity	●65AH
Lateral change battery	•
battery indicator with hour meter	•
half speed function in turning	•
Backrest height	●1220mm (48in)/1520mm (60in)
Water proof	•
Scale	•